



Statnett

Feeder and Substation Containment Proposal

November 8, 2024

Alex Anderson (PNNL)

Svein Olsen (Statnett)



PNNL is operated by Battelle for the U.S. Department of Energy

PNNL-SA-204041





Pacific
Northwest
NATIONAL LABORATORY

Feeder Configurations

U.S. DEPARTMENT OF
ENERGY **BATTELLE**

PNNL is operated by Battelle for the U.S. Department of Energy



European Feeder Configuration

Feeder

“Layers” of the Feeder

- energized by substation engine
- energized by Feeder 1
- energized by Feeder 2
- energized by Substation 1
- energized by 0.4 kV Substation 1
- energized by 0.23 kV Substation 1
- energized by Substation 2
- energized by 0.4 kV Substation 2

What?

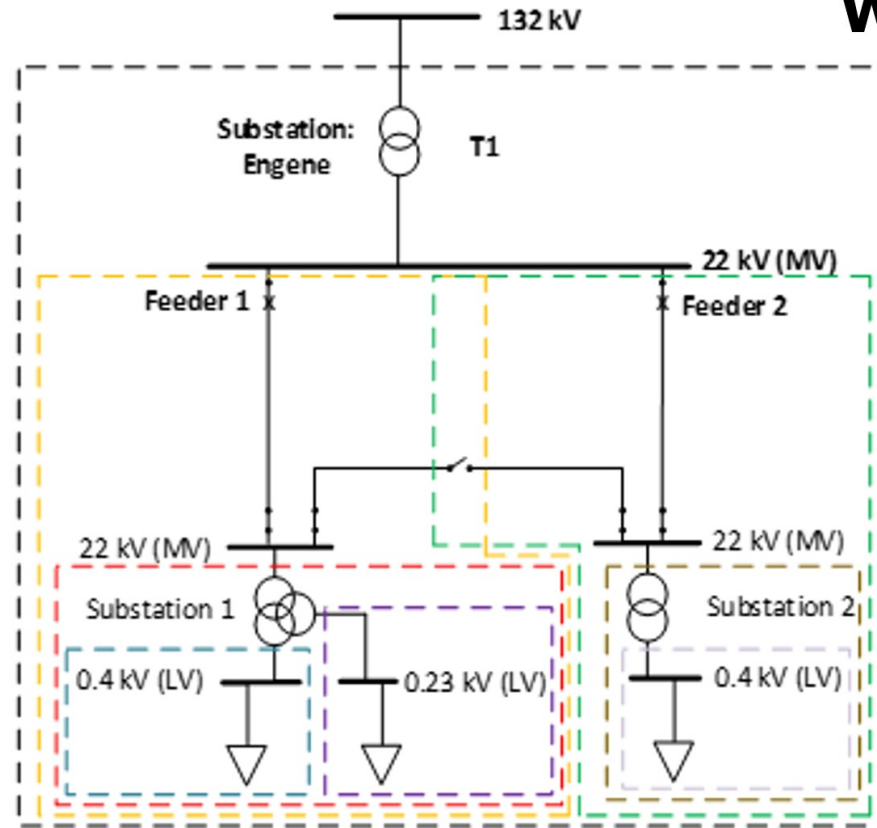

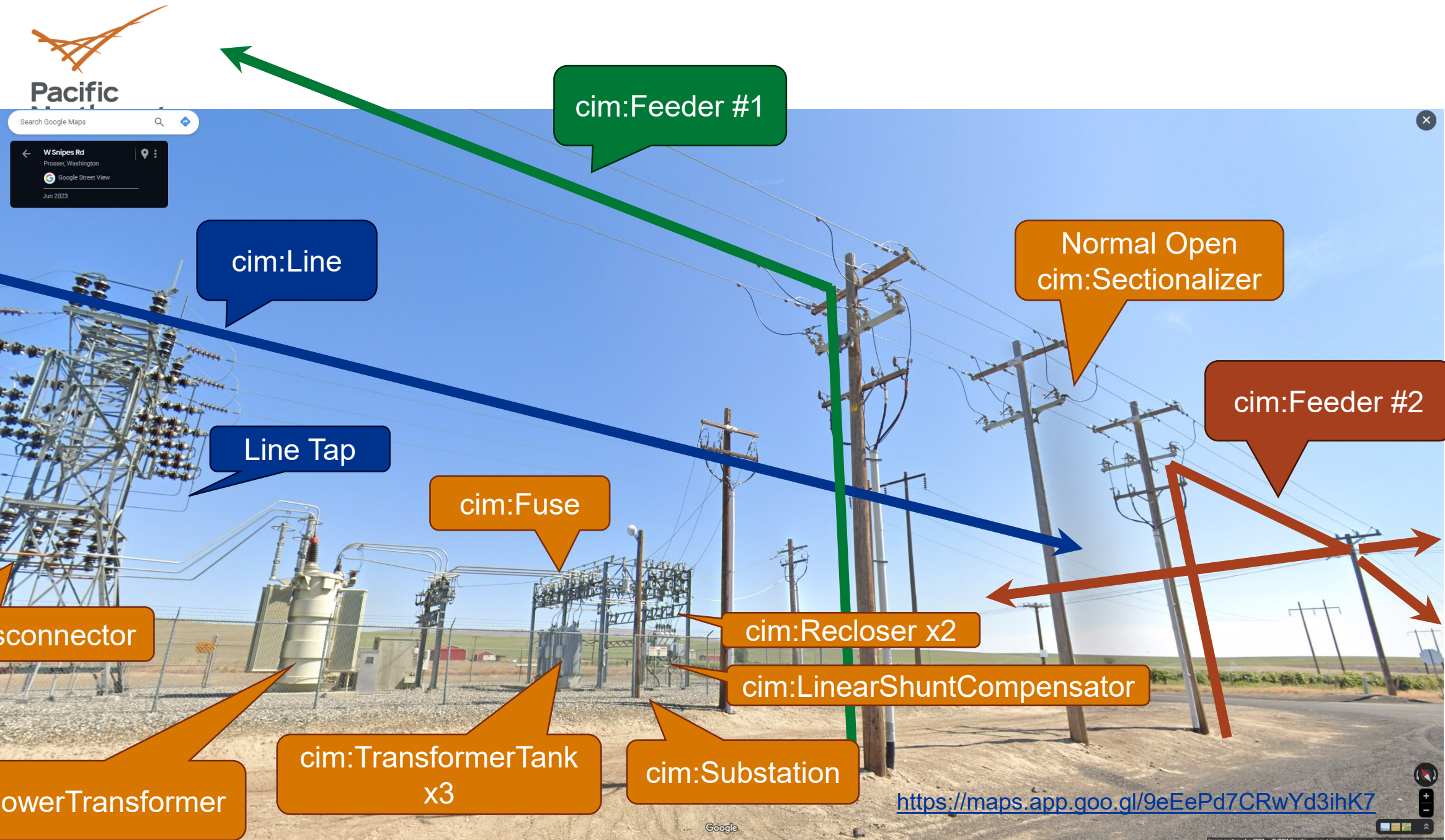

Pacific

Search Google Maps

W Snipes Rd
Prosser, Washington
Google Street View
Jun 2023

cim:Feeder #1

cim:Line

Normal Open
cim:Sectionalizer

cim:Feeder #2

Line Tap

cim:Fuse

cim:Disconnecter

cim:Recloser x2

cim:LinearShuntCompensator

cim:PowerTransformer

cim:TransformerTank
x3

cim:Substation

<https://maps.app.goo.gl/9eEePd7CRwYd3ihK7>

Google



cim:Substation

cim:VoltageLevel
115kV

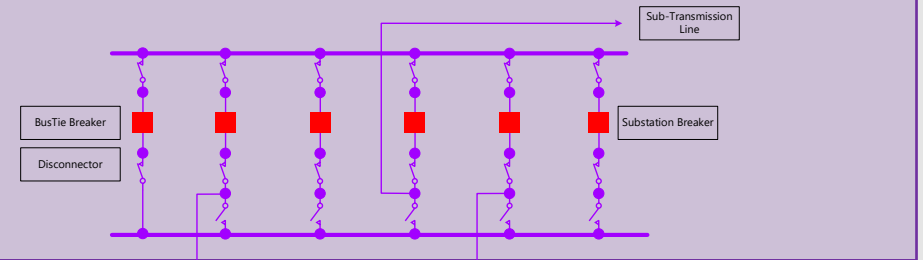

cim:VoltageLevel
12.47kV

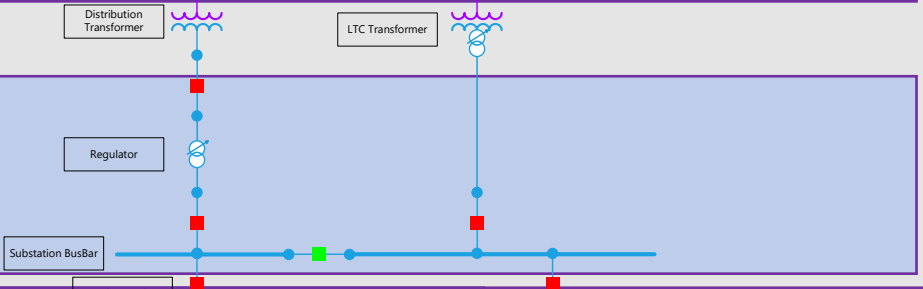

cim:Feeder

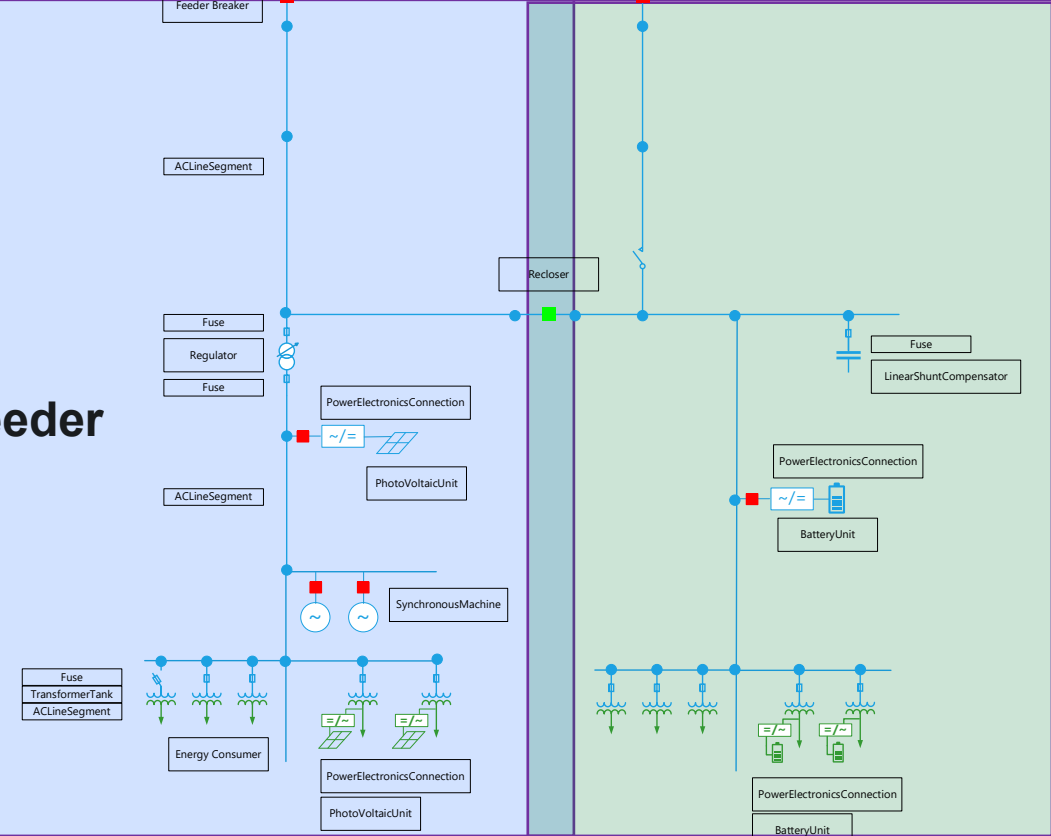

In GMDM profile and models generated through EPRI OpenDSS / GridAPPS-D, all equipment and nodes are associated with a single cim:Feeder container

Normal Switching Configuration

Triplex 2-ph
120/240V
secondary

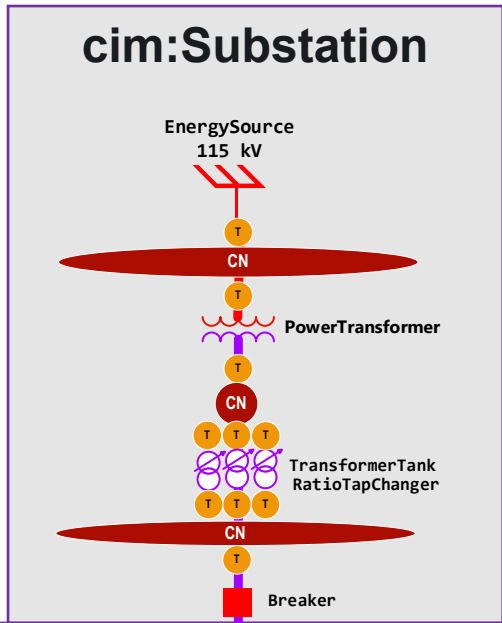

Normal
Open Switch

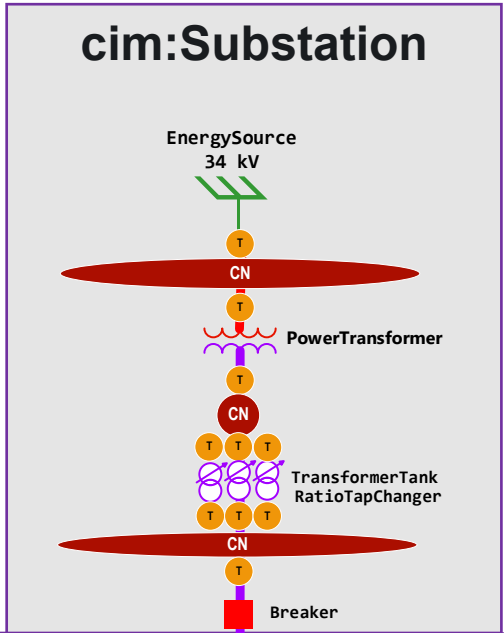

- CN CIM ConnectivityNode
- T CIM Terminal
- 115 kV
- 12.4 kV
- 120 V
- 3-φ
- 2-φ
- 1-φ

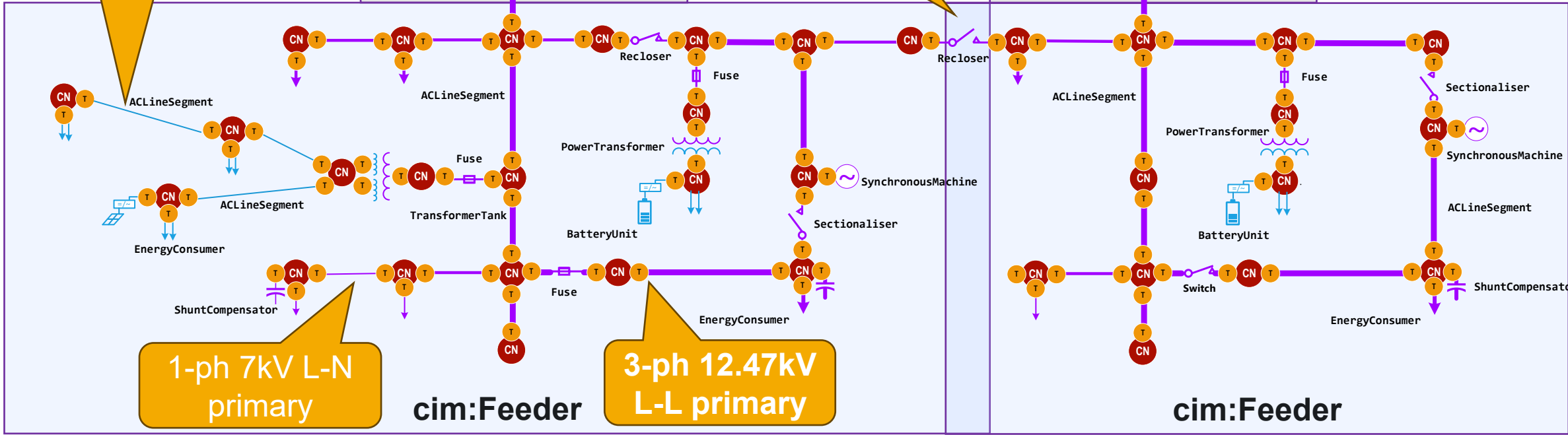

1-ph 7kV L-N
primary

3-ph 12.47kV
L-L primary



Abnormal Switching Configuration #1:

It is important to operators to know that a topological loop has been created

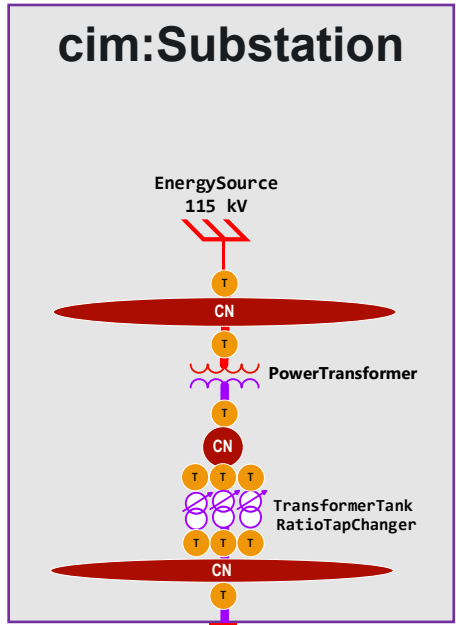

Loop

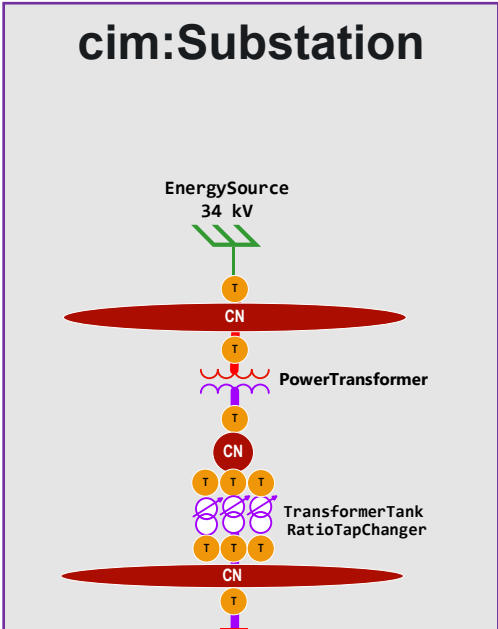

- CN CIM ConnectivityNode
- T CIM Terminal
- 115 kV
- 12.4 kV
- 120 V
- 3-φ
- 2-φ
- 1-φ

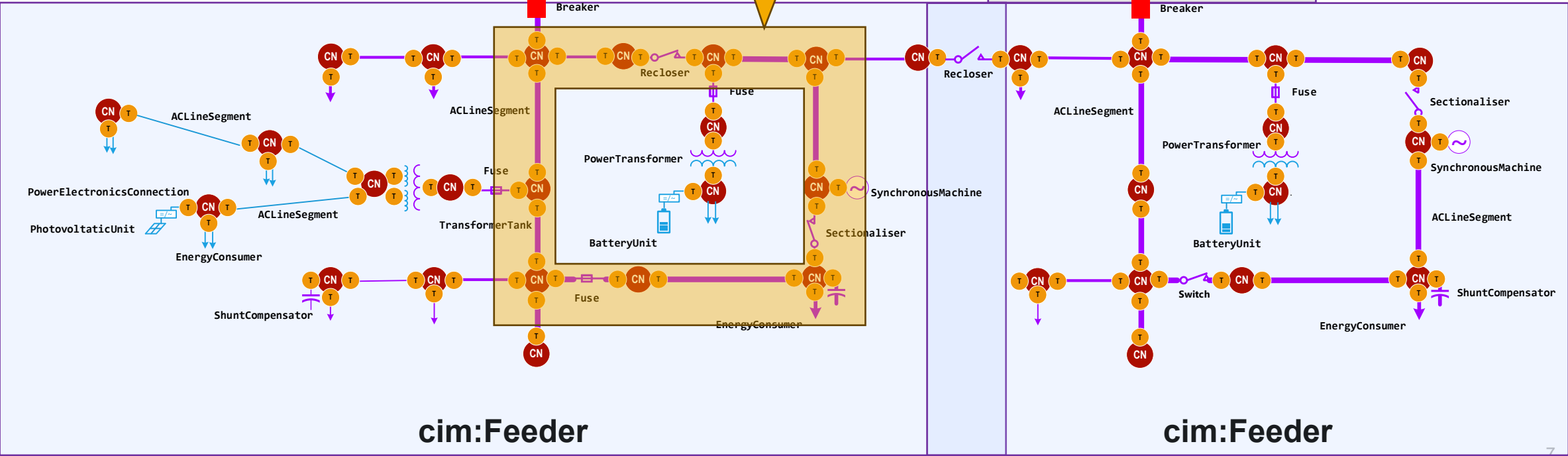



Abnormal Switching Configuration #2:
Part of Feeder 1 is energized by Sub 2.
We have no way to model this in CIM

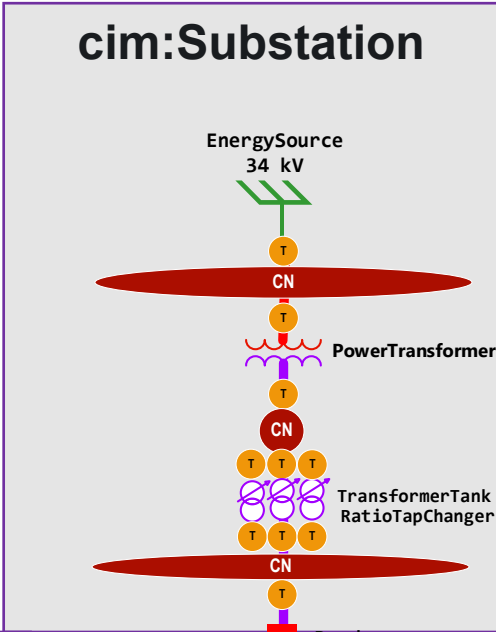
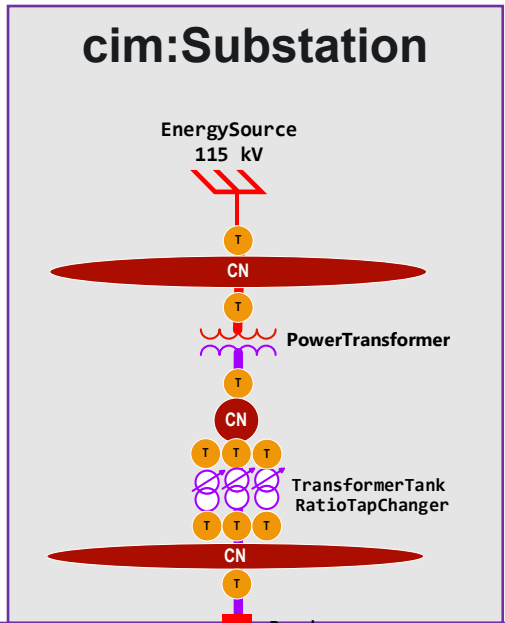

Energized by
Substation #2

- CN CIM ConnectivityNode
- T CIM Terminal
- 115 kV
- 12.4 kV
- 120 V
- 3-φ
- 2-φ
- 1-φ

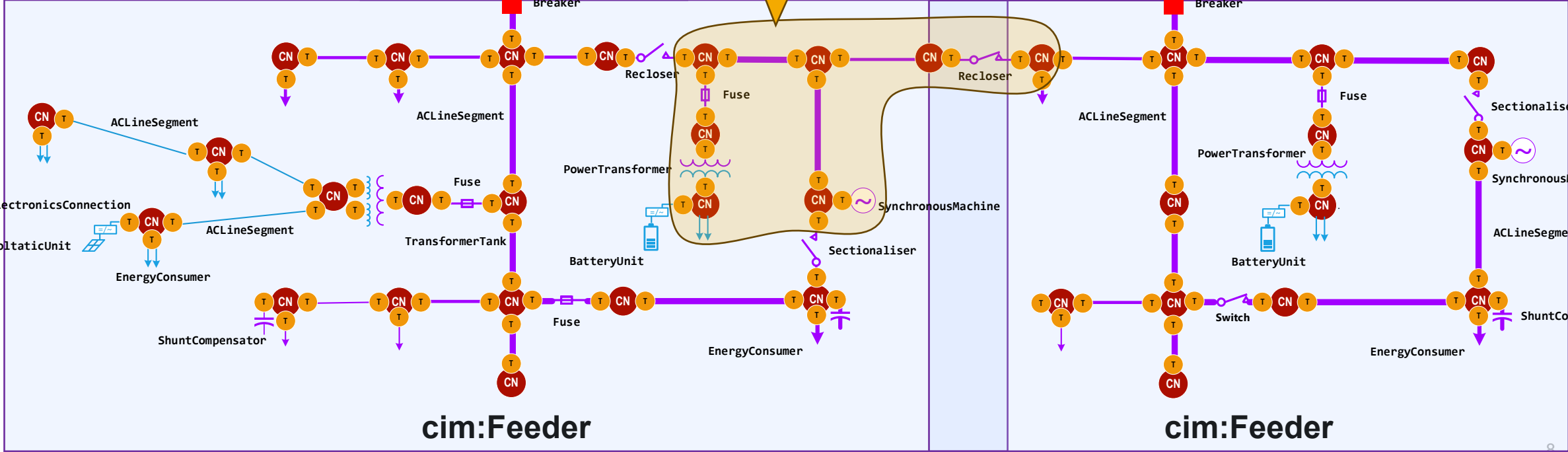

Existing ConnectivityNode Containment

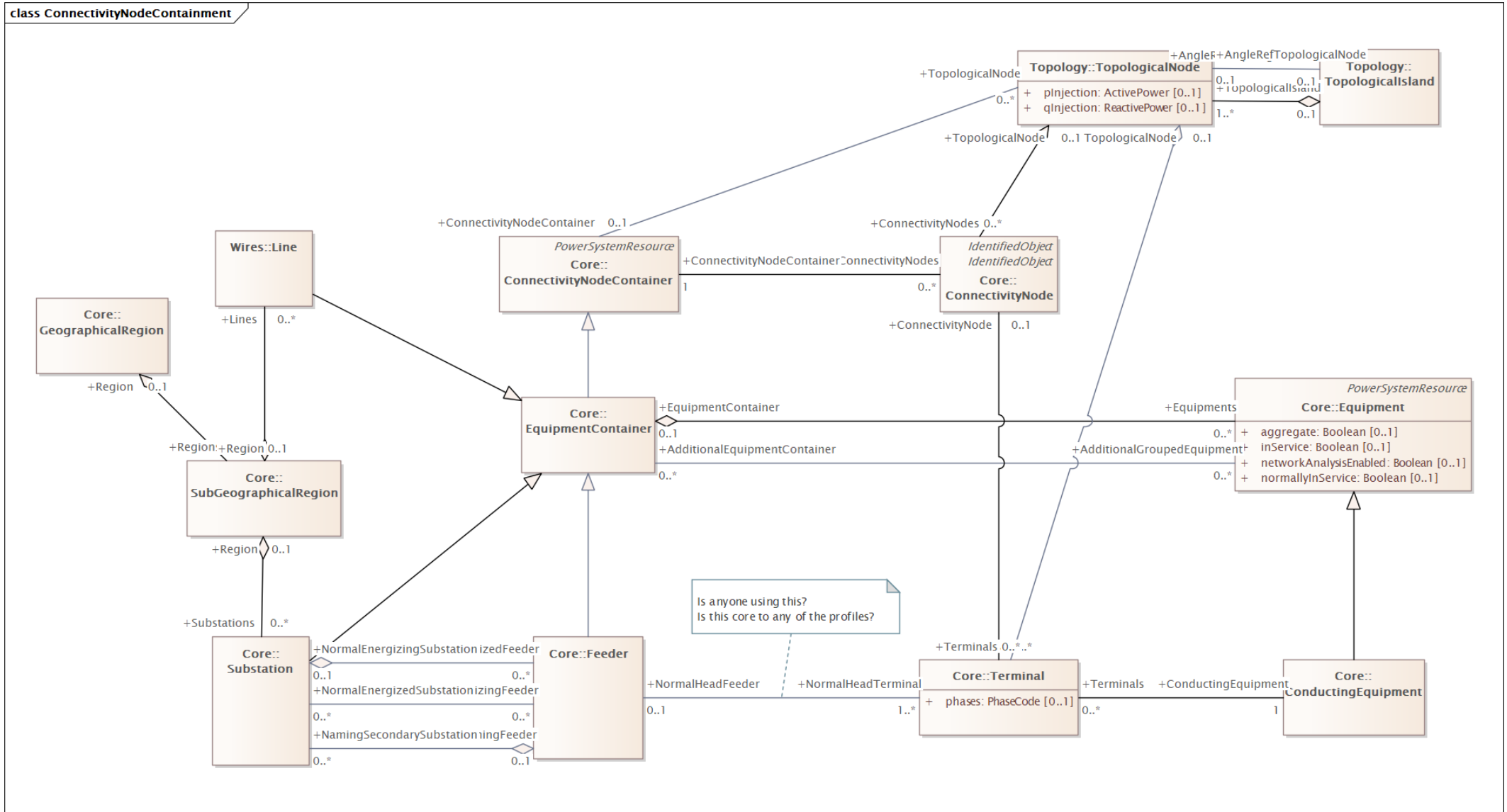

Model Query Path for GridAPPS-D

class ConnectivityNodeContainment

In GMDM profile, Feeder is EquipmentContainer and ConnectivityNodeContainment

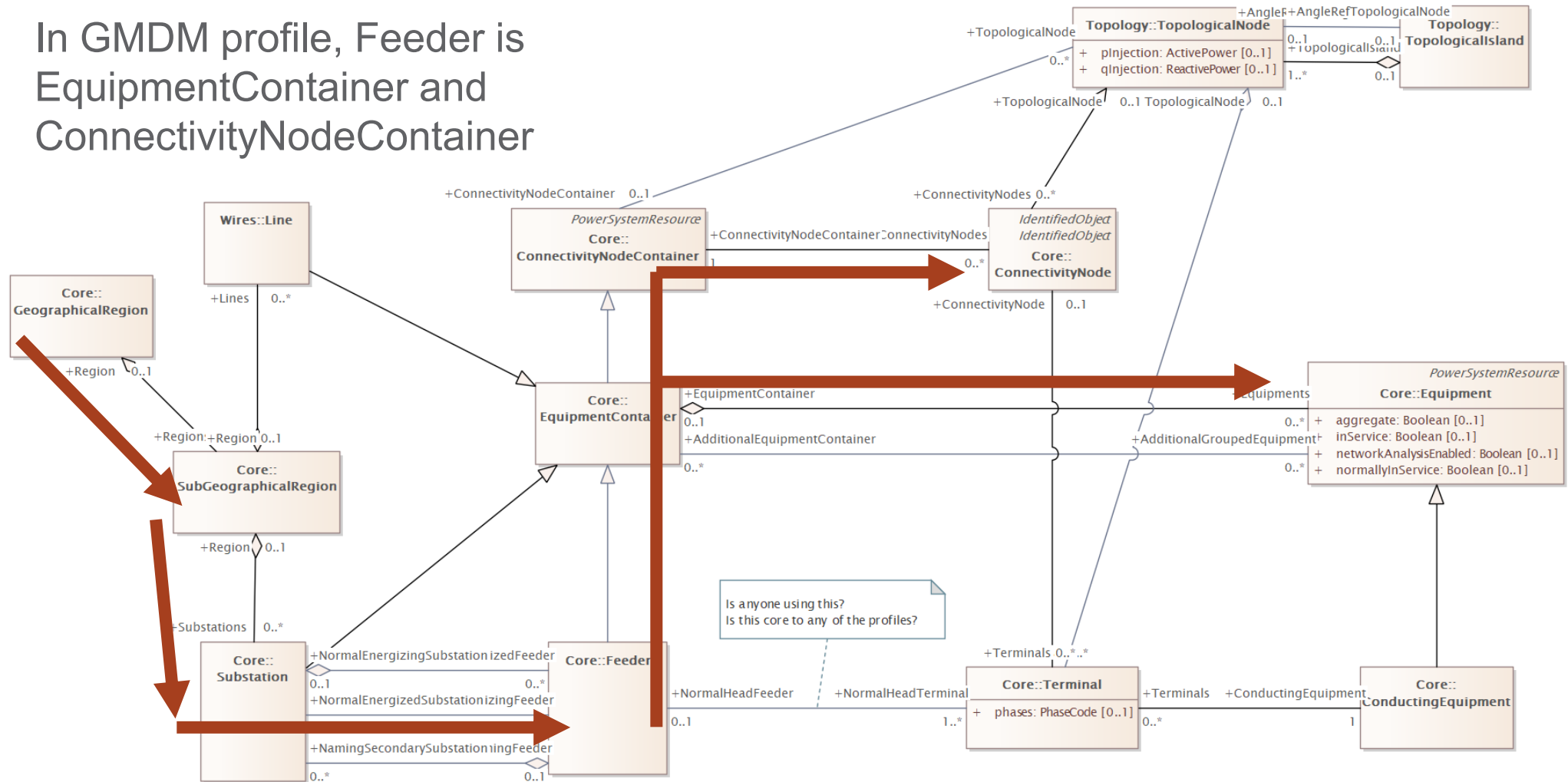

GridAPPS-D Distributed Architecture Switch-Delimited Topological Areas

ConnectivityNode, Equipment, and Measurement objects mapped to persistent areas defined from feeder connectivity

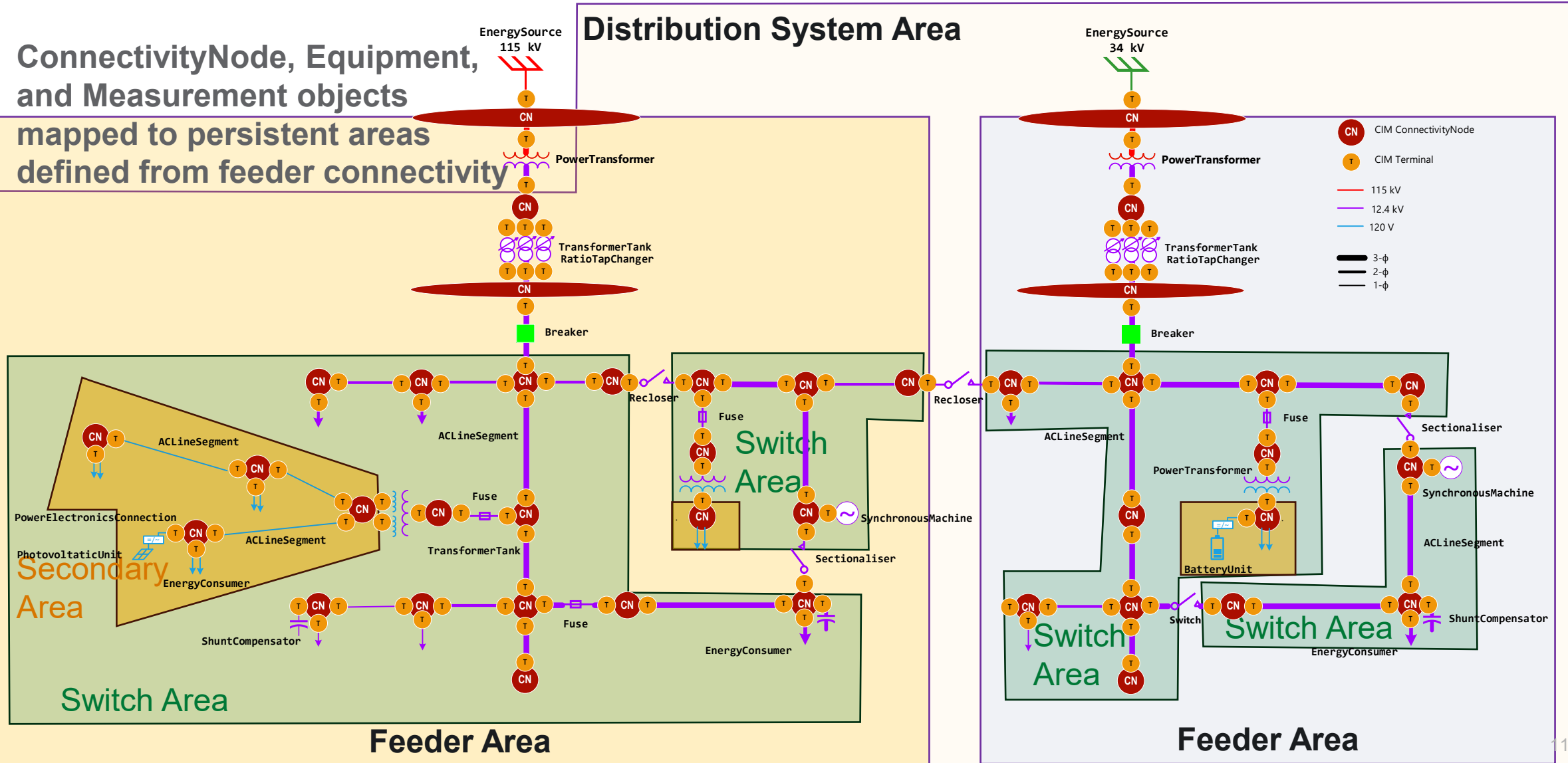

Meshed Secondary Spot Networks

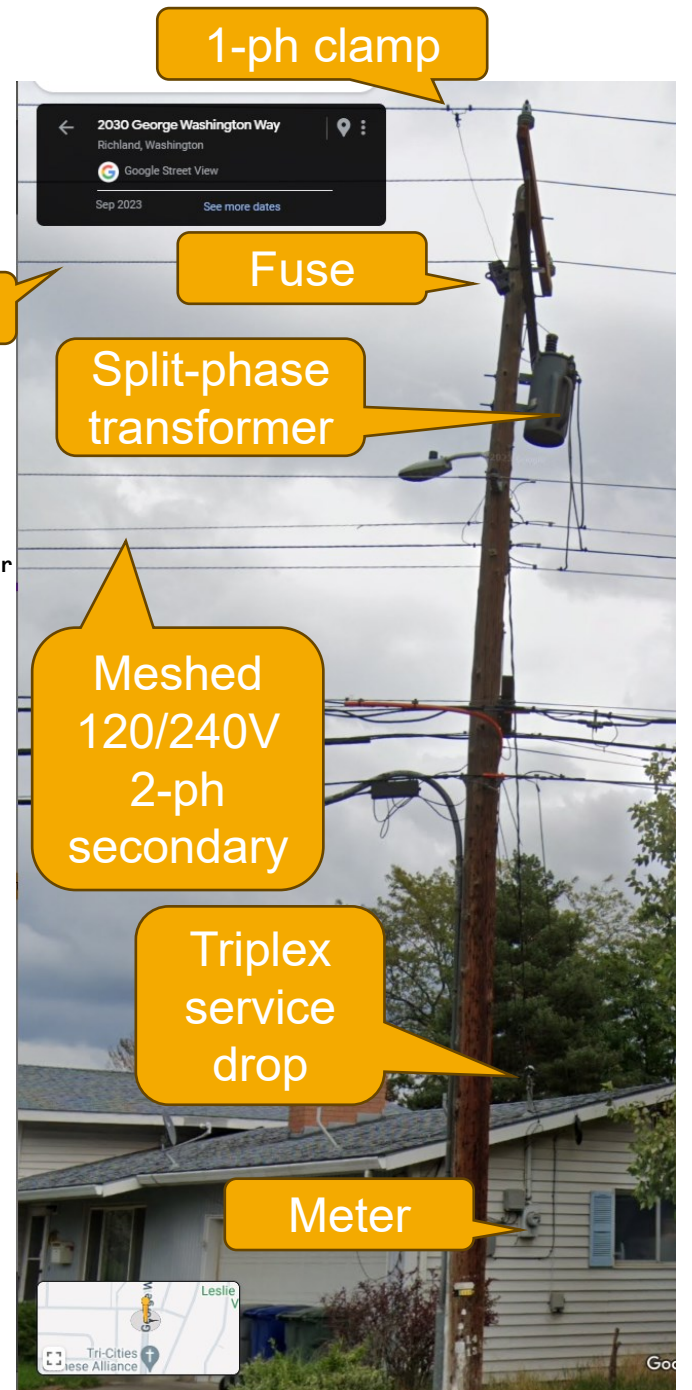
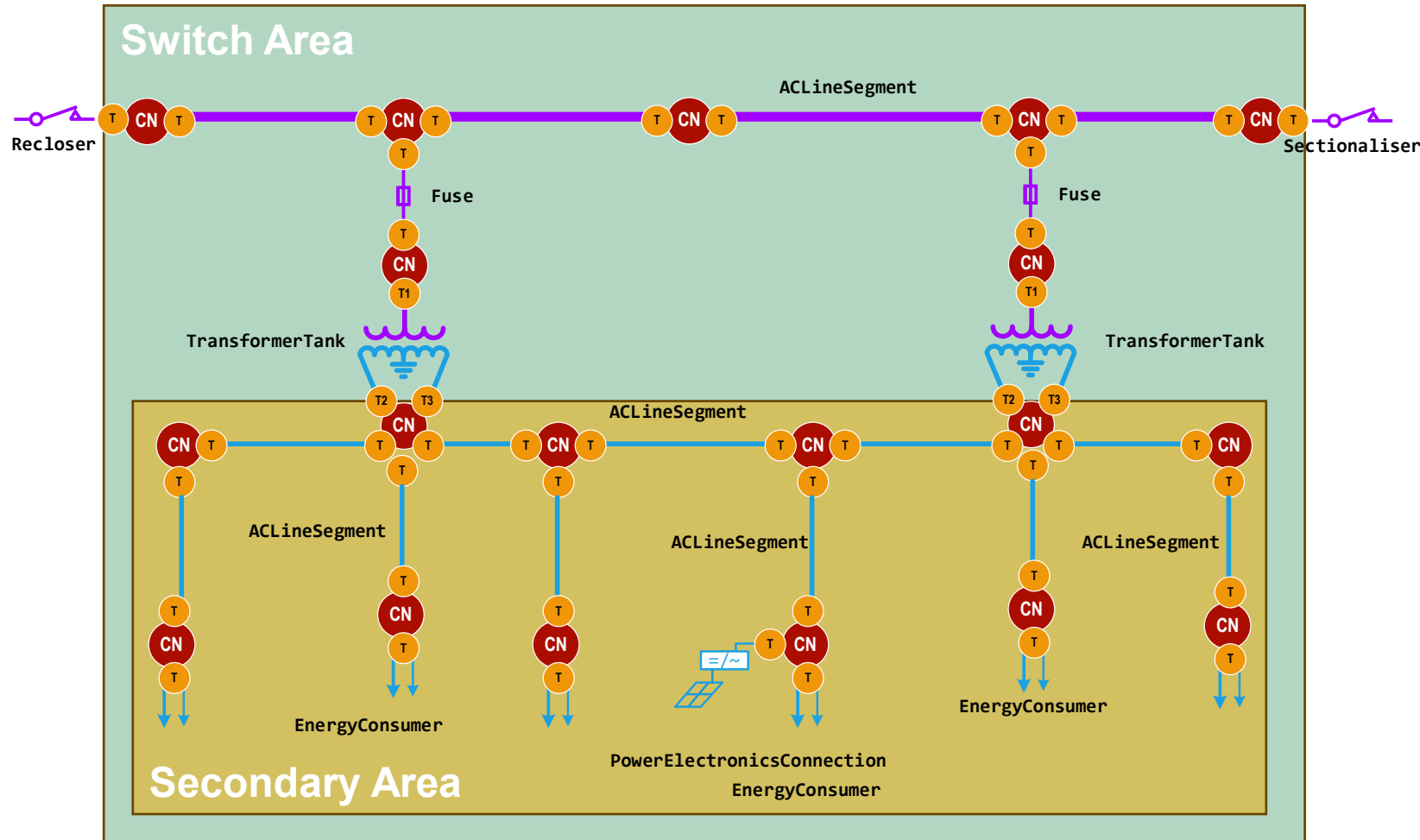



Pacific
Northwest
NATIONAL LABORATORY

Proposed Change Request

U.S. DEPARTMENT OF
ENERGY **BATTELLE**

PNNL is operated by Battelle for the U.S. Department of Energy



SubSchedulingArea (Existing)

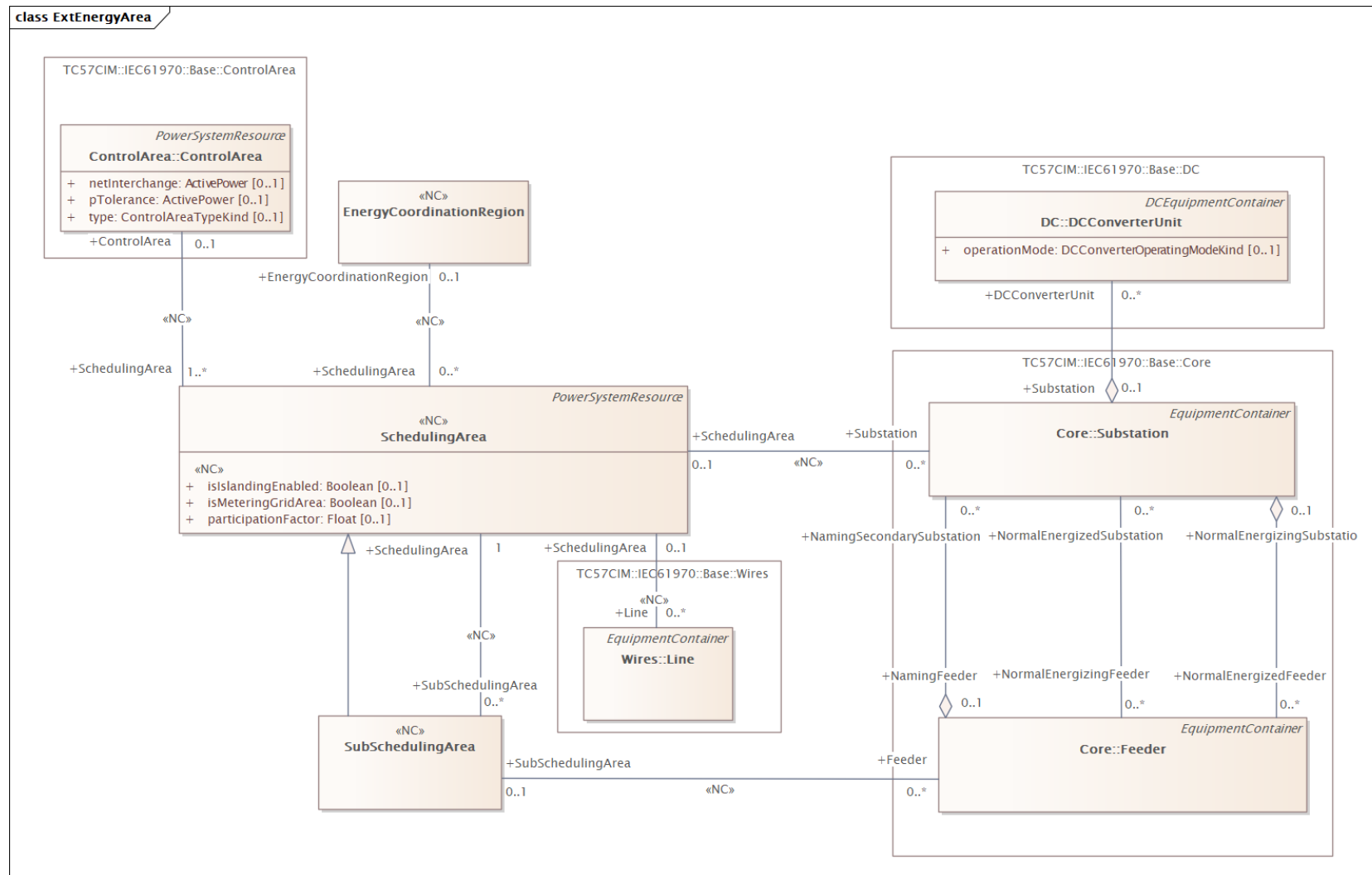

SubSchedulingArea (Proposed)

class SubSchedulingArea

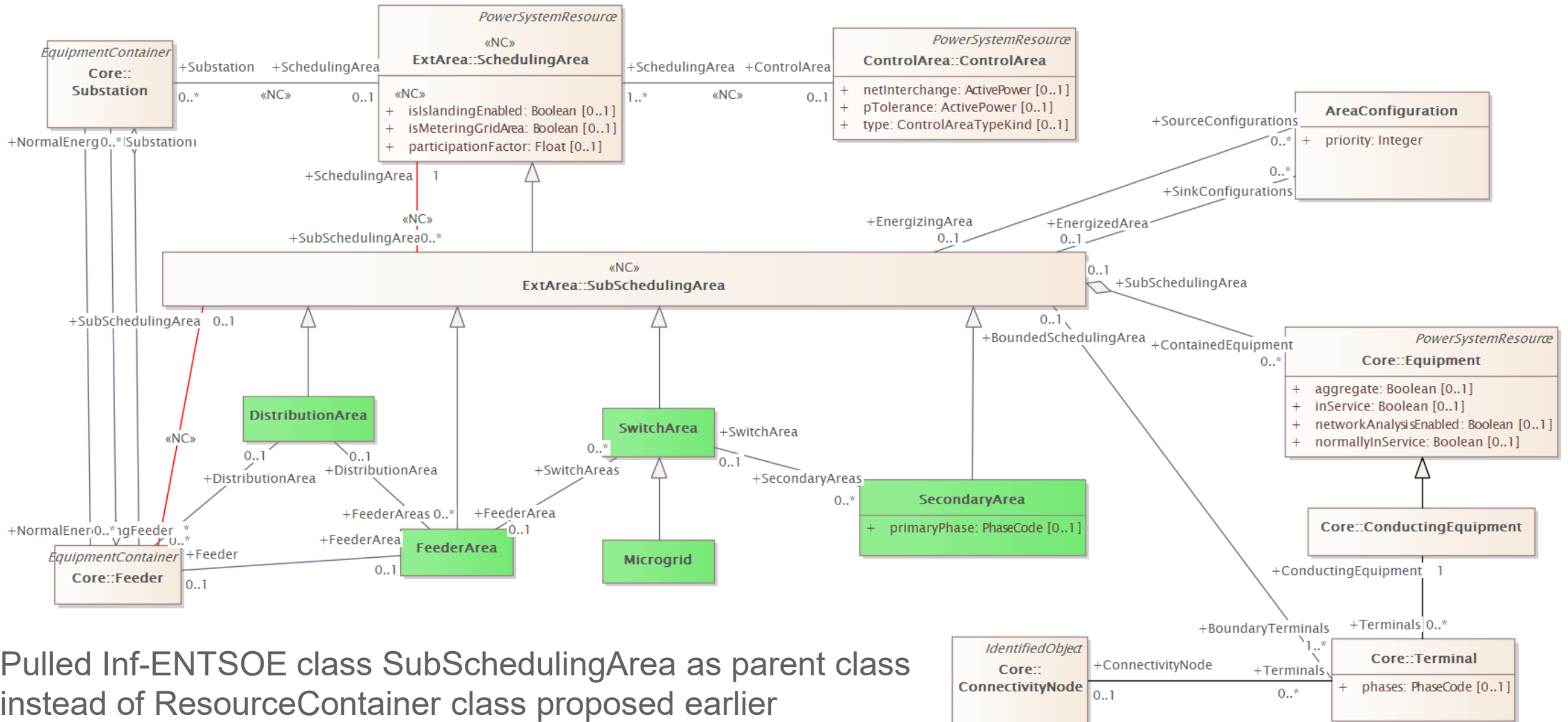

Pulled Inf-ENTSOE class SubSchedulingArea as parent class instead of ResourceContainer class proposed earlier

Association to Equipment

- Should association be to Equipment or ConductingEquipment?

Association to ConductingEquipment:

- ACLineSegment
- PowerTransformer
- PowerElectronicsConnection
- ShuntCompensator
- Fuse
- Etc.

Association to Equipment:

- All types of ConductingEquipment, plus
- TransformerTank
- PowerElectronicsUnit
- ProtectionEquipment
- Etc.

Class Descriptions

- SubSchedulingArea

- An area that is a part of another scheduling area. Typically part of a Transmission System Operator (TSO) scheduling area operated by a Distributed System Operator (DSO) or a Close Distributed System Operator (CDSO). ~~This includes microgrid concept. A sub-scheduling area can contain other sub-areas. A sub-scheduling area leaf will form the smallest entity of any given energy area.~~
- *The SubSchedulingArea is a persistent connectivity-based containment defined by a set of boundary Terminal objects. The BoundaryTerminal association is to the near-side terminal of clearly-defined electrical boundaries forming a local power system with one or more points of common coupling. Each piece of Equipment can be associated with one SubSchedulingArea in which it is contained. The boundaries of the SubSchedulingArea are specified through the Terminals of equipment forming the boundary (such as a Recloser or PowerTransformer) and do not change through topology changes via switching actions.*
- (note: Removing self-association between SchedulingArea and SubSchedulingArea)



Class Descriptions

- **DistributionArea**
 - A persistent connectivity-based containment of medium-voltage and high-voltage distribution Equipment with clearly defined electrical boundaries based on terminals of boundary equipment in a distribution substation or multiple substations. The DistributionArea provides the highest-level description of the equipment controlled by the Distribution System Operator (DSO).
- **FeederArea**
 - A persistent connectivity-based containment of medium-voltage distribution Equipment with clearly defined electrical boundaries based on electrical connectivity of a distribution feeder.
 - The FeederArea contains all medium voltage equipment not contained in a SwitchArea or Substation / Bay. It also includes all Sectionalisers, Reclosers, and all other poletop and pad-mounted switchgear that form the boundary of a SwitchArea. It also includes all equipment between the feeder head terminal and the first switching device if the substation breaker is not included in Feeder EquipmentContainer.



Class Descriptions

- SwitchArea

- A persistent connectivity-based containment of medium-voltage distribution Equipment with clearly defined electrical boundaries formed by one or more Switch objects.
- The SwitchArea contains all conductors, fuses, poletop equipment, and vault equipment. It also contains all secondary service transformers not contained in a SecondarySubstation.

- Microgrid

- A persistent connectivity-based containment of distribution equipment that 1) has clearly-defined electrical boundaries formed by one or more point of common coupling Switch objects and 2) that acts as a single controllable entity which can be operated in grid-connected or islanded mode.
- This covers both utility-owned distribution microgrids and customer-owned facility microgrids as defined in IEV 617-04-22.



Class Descriptions

- **SecondaryArea**
 - A persistent connectivity-based containment of low-voltage distribution Equipment and customer-owned Equipment with clearly defined electrical boundaries formed by one or more PowerTransformer objects.
- **SecondaryArea.primaryPhase (PhaseCode)**
 - Used to represent the ABC phase to which the secondary split-phase transformer is connected in North American systems. For secondary areas served by a center-tap transformer, the phase connection of equipment will generally be SinglePhaseKind.s1 or SinglePhaseKind.s2, and it is not readily apparent what phase serves the loads at the medium voltage level.

Harmonization with FunctionBlock

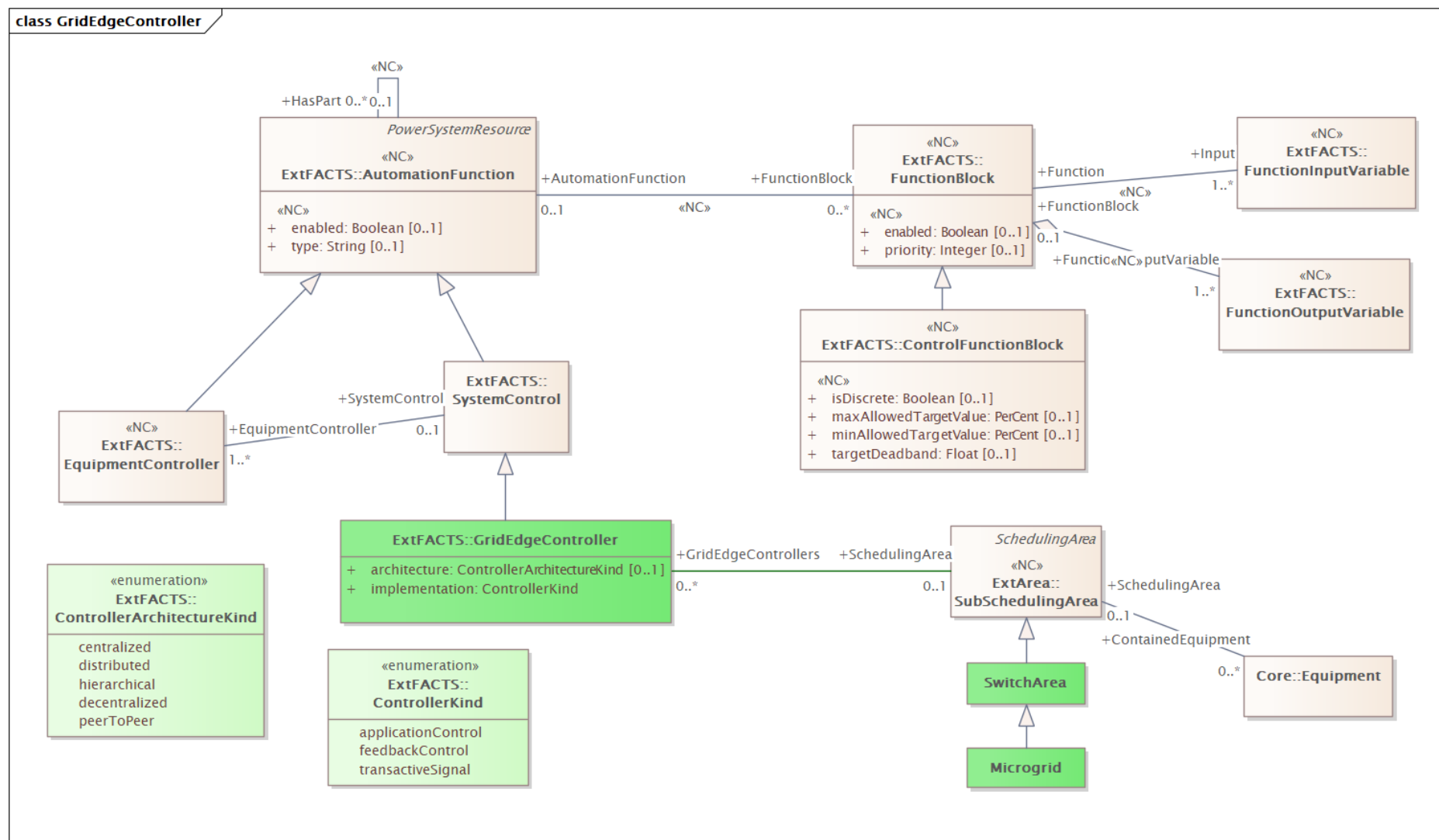



Complete Feeder Control View

class Control

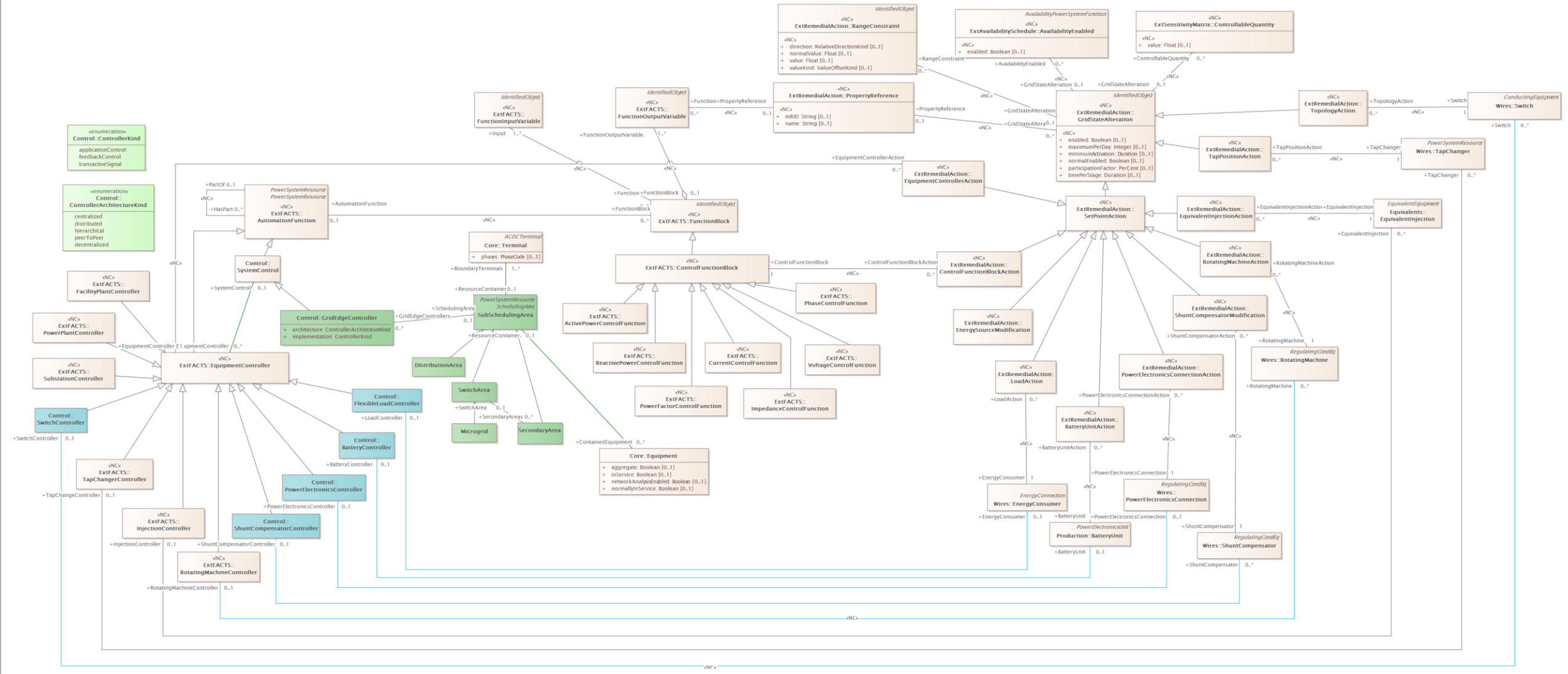

New Model Query Path for Distributed Areas

class SubSchedulingArea

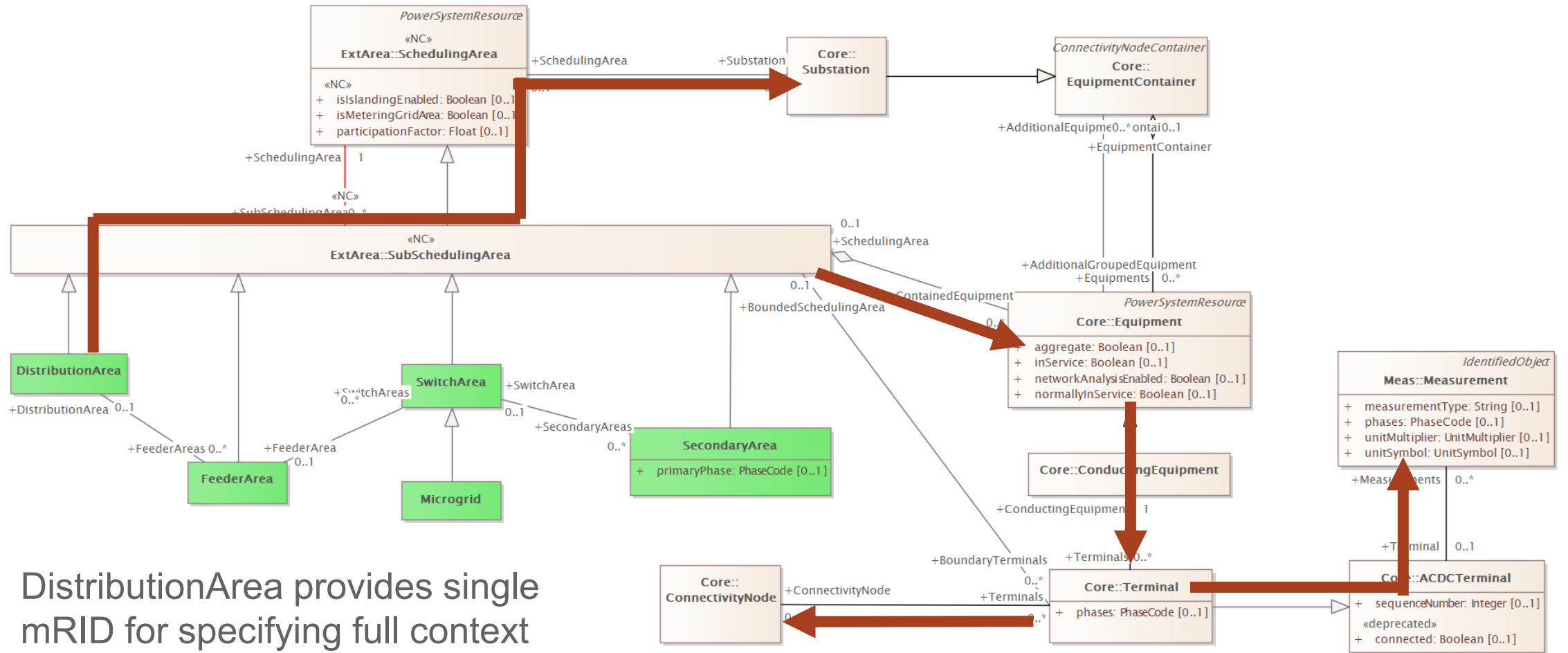

DistributionArea provides single mRID for specifying full context for multiple feeders